

SPECIFICATIONS SHEET

A050 – 1/2 in. METAL PUMP

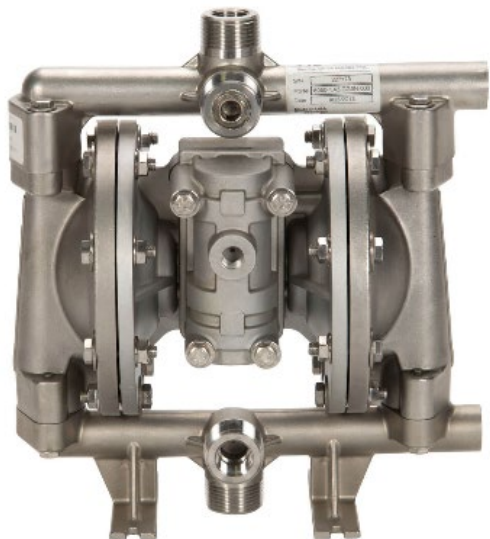

Air Inlet
1/4" FNPT

Liquid Inlet
1/2"

Liquid Discharge
1/2"

Connection Type
FNPT/FBSPT (Threaded)

Max Suction Lift Capability
15 ft-H₂O (4.6 m-H₂O) Dry
31 ft-H₂O (9.4 m-H₂O) Wet

Max Flow Rate
15 gpm (56.8 lpm)

Max Pressure
120 psi (8.2 bar)

Max Solids Dia.
1/8" (3.2 mm)

Disp. Per Stroke
0.03 gal (0.04 L)

Weight
Alum: 10 lbs (4.5 kg)
SS: 20 lbs (9.1 kg)

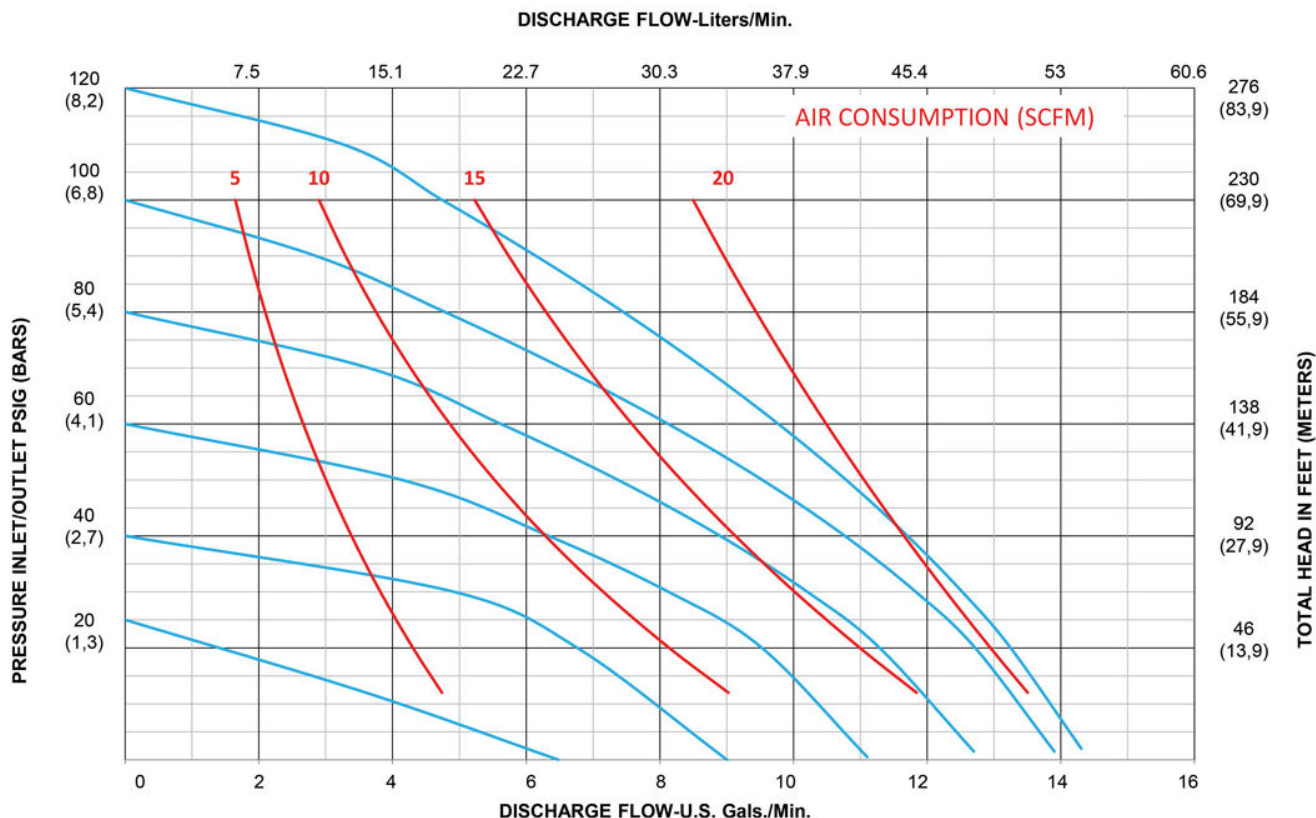

SPECIFICATIONS SHEET

A050 – 1/2 in. METAL PUMP

Aluminum Center Section

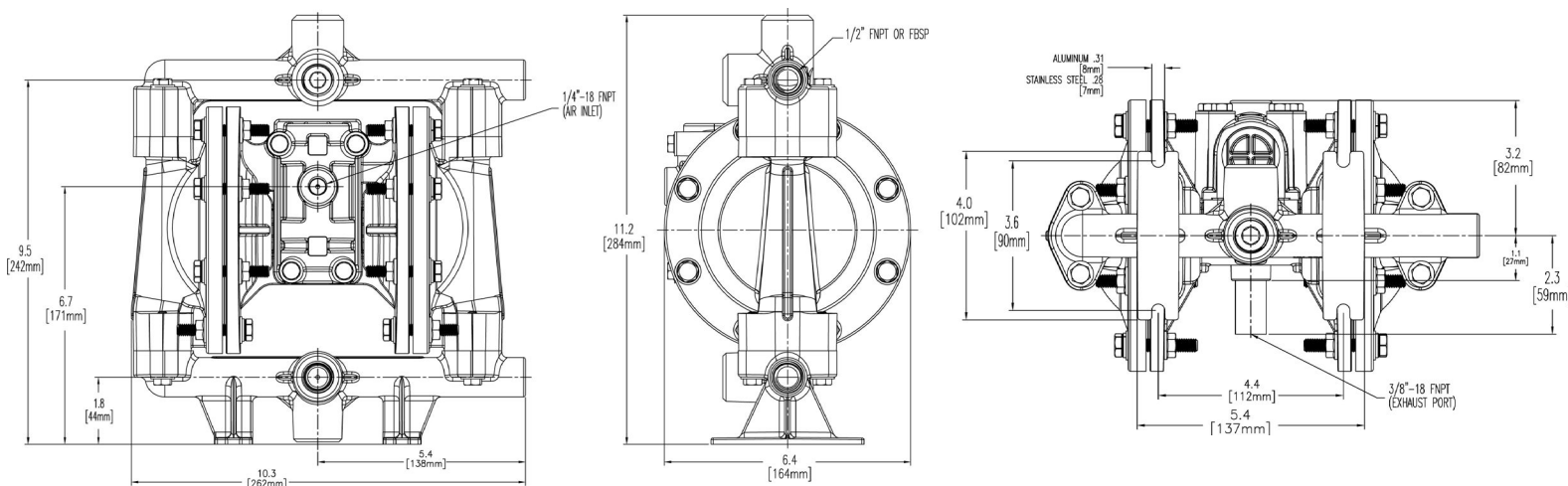

Polypropylene Center Section

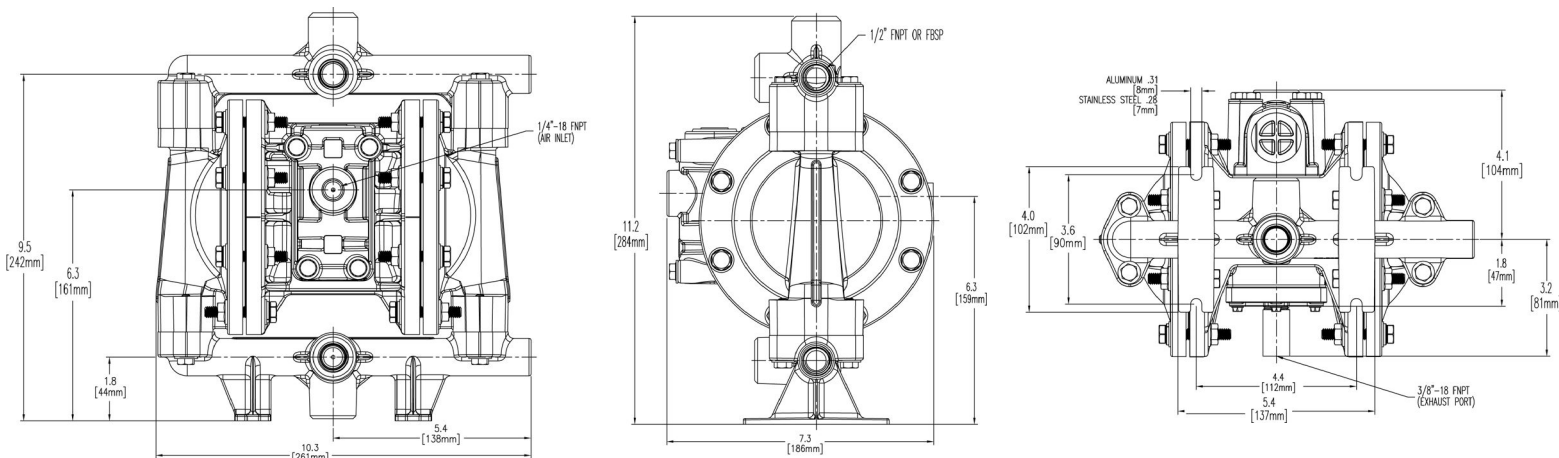

Popular Models

A050-NAA-GGPN-S30	NPT, Bunalast™ Diaphragm, Bunalast™ Ball, Polypropylene Seat, Buna-N O-Ring, Zinc Plated Hardware
A050-NAA-SSPE-S30	NPT, Santoprene® Diaphragm, Santoprene® Ball, Polypropylene Seat, EPDM O-Ring, Zinc Plated Hardware
A050-NAA-TTYT-S30*	NPT, PTFE Diaphragm, PTFE Ball, Polypropylene Seat, FKM O-Ring, Zinc Plated Hardware
A050-NA3-SS3E-S70	NPT, Santoprene® Diaphragm, Santoprene® Ball, PVDF Seat, EPDM O-Ring, Stainless Steel Hardware
A050-NA3-TT3T-S70*	NPT, PTFE Diaphragm, PTFE Ball, PVDF Seat, PTFE O-Ring, Stainless Steel Hardware

*Pump model is part of the Ready2Ship Program



PSG
All-Flo
22069 Van Buren Street
Grand Terrace, CA 92313, USA

P: +1 (440) 354-1700
F: +1 (440) 354-9466

all-flo.com

