

# SPECIFICATIONS SHEET

## A025 – 1/4 in. PLASTIC PUMP



**Air Inlet**  
1/4" FNPT

**Liquid Inlet**  
1/4"

**Liquid Discharge**  
1/4"

**Connection Type**  
FNPT/FBSPT (Threaded)

**Max Suction Lift Capability**  
14 ft-H<sub>2</sub>O (4.2 m-H<sub>2</sub>O) Dry  
28 ft-H<sub>2</sub>O (8.5 m-H<sub>2</sub>O) Wet

**Max Flow Rate**  
5.7 gpm (21.6 lpm)

**Max Pressure**  
120 psi (8.2 bar)

**Max Solids Dia.**  
1/16" (1.6 mm)

**Disp. Per Stroke**  
0.01 gal (0.04 L)

**Weight**  
Poly: 2.6 lbs (1.2 kg)  
PVDF: 3.8 lbs (1.7 kg)

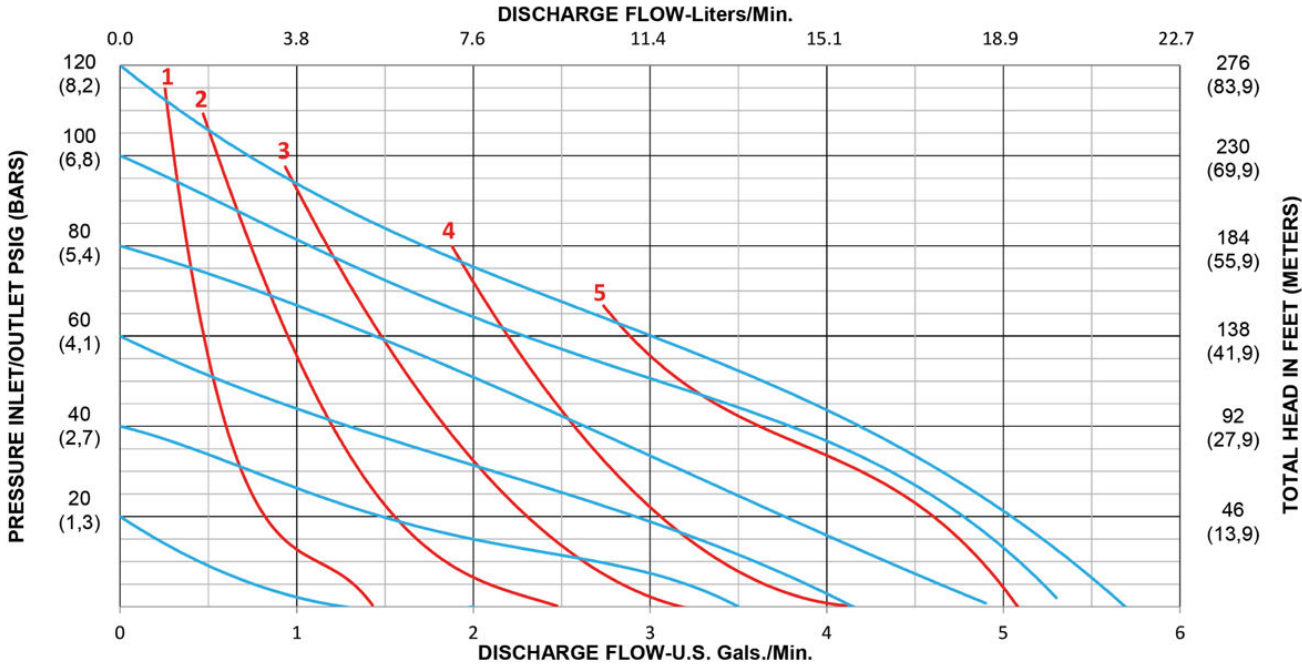

PSG  
All-Flo  
22069 Van Buren Street  
Grand Terrace, CA 92313, USA

P: +1 (440) 354-1700  
F: +1 (440) 354-9466

all-flo.com



# SPECIFICATIONS SHEET

## A025 – 1/4 in. PLASTIC PUMP

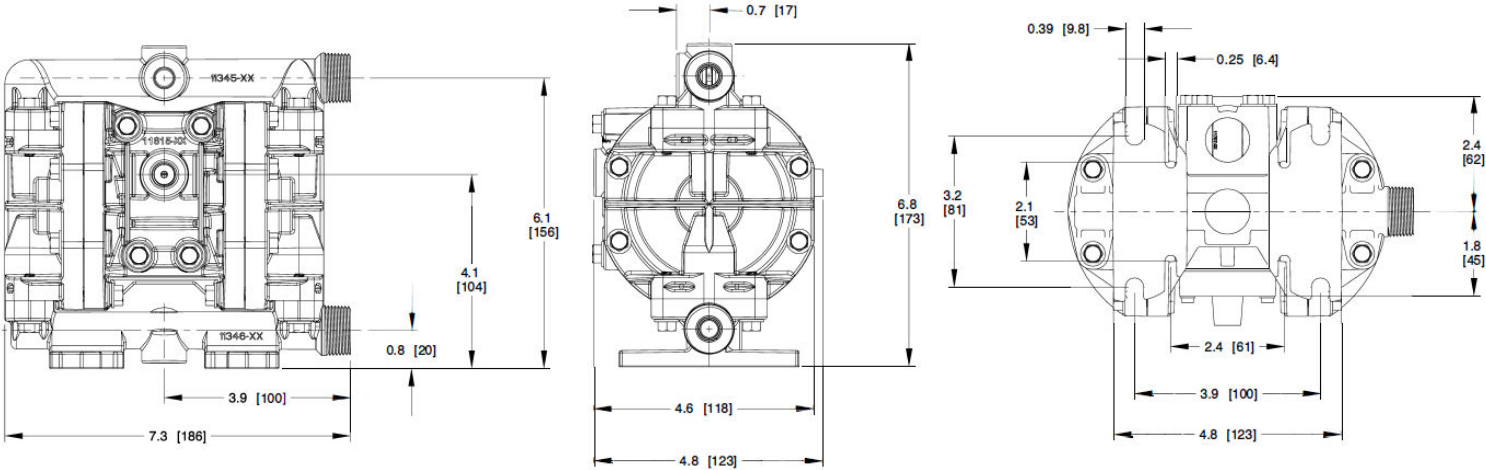

Construction	
<b>Wet End:</b>	Polypropylene, PVDF, Conductive Polypropylene, Conductive PVDF
<b>Air End:</b>	Polypropylene
<b>Diaphragms:</b>	Bunast™, PTFE, Santoprene®
<b>Balls:</b>	Bunast™, PTFE, Santoprene®
<b>Seats:</b>	Polypropylene, PVDF
<b>O-Rings:</b>	Buna-N, EPDM, PTFE, FKM
<b>Hardware:</b>	PTFE Coated Stainless Steel, Stainless Steel
<b>Muffler:</b>	Plastic

Popular Models	
<b>A025-SPP-GGPN-S70</b>	NPT(BSP), Bunast™ Diaphragm, Bunast™ Ball, Polypropylene Seat, Buna-N O-Ring, Stainless Steel Hardware
<b>A025-SPP-SSPE-S70*</b>	NPT(BSP), Santoprene® Diaphragm, Santoprene® Ball, Polypropylene Seat, EPDM O-Ring, Stainless Steel Hardware
<b>A025-SPP-TTPV-S70*</b>	NPT(BSP), PTFE Diaphragm, PTFE Ball, Polypropylene Seat, FKM O-Ring, Stainless Steel Hardware
<b>A025-SPK-SSKE-S70</b>	NPT(BSP), Santoprene® Diaphragm, Santoprene® Ball, PVDF Seat, EPDM O-Ring, Stainless Steel Hardware
<b>A025-SPK-TTKT-S70</b>	NPT(BSP), PTFE Diaphragm, PTFE Ball, PVDF Seat, PTFE O-Ring, Stainless Steel Hardware

\*Pump model is part of the Ready2Ship Program