



**MUNSCH**  
*Plastic Pumps for Aggressive Media*

# Chemical pumps

**Vertical chemical pump  
Type TNP-KL**

In PP/PE-UHMW/PVDF  
Vertical setting depths up to 3000 mm

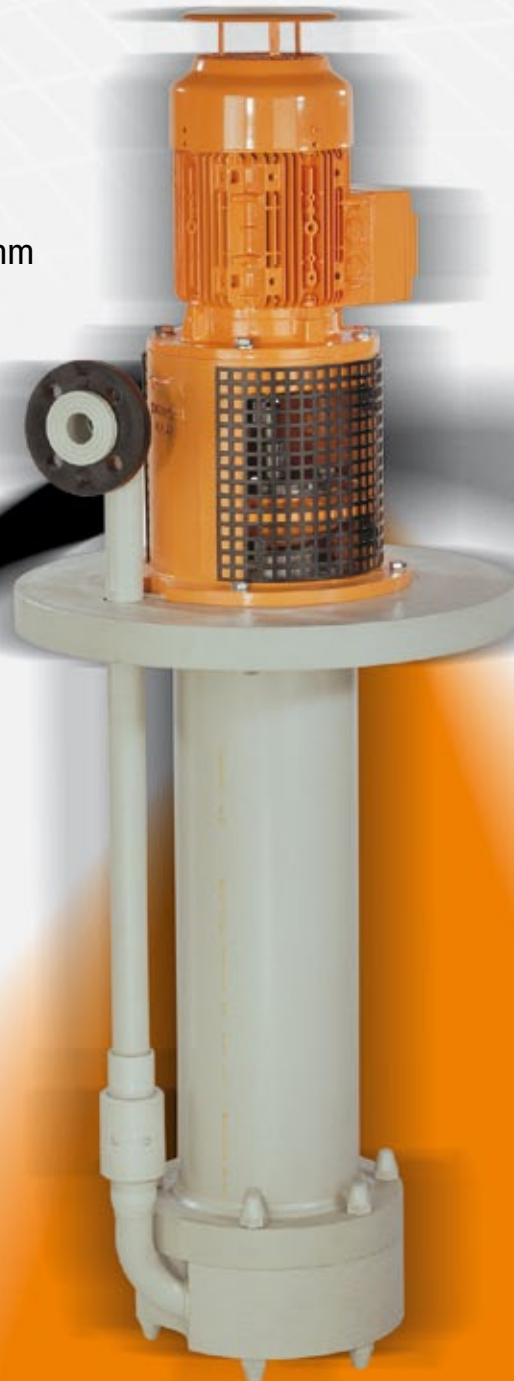

# Vertical chemical pump TNP-KL

## ► Applications

Type TNP-KL vertical chemical pumps are specifically designed to handle acids, alkalines or chemically contaminated fluids with or without solids. Typical applications include the chemical and metal finishing industries, steel and stainless steel pickling lines, evaporation and regeneration units, wet flue gas scrubbing downstream of waste incinerators as well as exhaust gas scrubbing and scrubber effluent treatment.

## ► Construction

Vertical, single-stage, centrifugal pump with volute casing and radial impeller, nominal pressure PN 10, for wet-end installation; dry-end installation possible (see Fig. 3.3).

## ► Materials

Part designation	Standard material range		
	PP	PE-UHMW	PVDF
Pump casing	PP	PE-UHMW	PVDF
Casing cover	PP	PE-UHMW	PVDF
Pump shaft	St		
Impeller	PP <sup>1)</sup>	PE-UHMW <sup>1)</sup>	PVDF <sup>1)</sup>
Plain bearing	SSiC		
Bearing lantern	GG		
Secondary seals <sup>2)</sup>	FPM		
Shaft protection sleeve	PP	PP	PVDF
Column pipe	PP	PP	PVDF
Suspension pipe	PP	PP	PVDF
Casing flange	PP	PP	PVDF
Sole plate	PP	PP	PVDF

1) Material combinations possible

2) Alternatives (depending on fluid pumped): EPDM or more significant. Special materials on request.

PP	Polypropylene
PE-UHMW	ultrahigh-molecular polyethylene
PVDF	Polyvinylidene fluoride
SSiC	High-purity silicon carbide
FPM	Fluoroelastomer
EPDM	Ethylene propylene diene elastomer
PTFE	Polytetrafluoroethylene

## ► Performance data for 50/60 Hz operation<sup>3)</sup>

Pump capacity [Q] up to	600 m <sup>3</sup> /h
Total differential head [H] up to	90 m
Motor rating [P] up to	55 kW
Vertical setting depths <sup>4)</sup> [l] up to	3000 mm
Diameter of discharge nozzle	DN 25 up to DN 150

3) Performance data for standard pumps; extended performance ranges on request

4) Extension with suction pipe up to 4600 m is possible

## ► Shaft seal

Labyrinth seal; single mechanical seal, double mechanical seal on request.

## ► Plain bearing lubrication

Standard: internal flushing with fluid pumped; optionally external flushing source.

## ► Flange connection

Standard design with stub end and backing flange to DIN, optionally to ANSI or JIS.

## ► Drive

Three-phase a.c. motor, frame type V1 with canopy to IEC, BS or NEMA; type of protection, type of enclosure and motor voltage according to customer's specifications.

## ► Coating

**Highly resistant surface coating:**

- Base coat: epoxy resin  
Coat thickness 60-80 micrometer
  - Top coat: polyurethane  
Coat thickness 60-80 micrometer
- Total coat thickness: 130-150 micrometer  
Painting and special painting on request

## Maximum allowable service pressures and temperatures

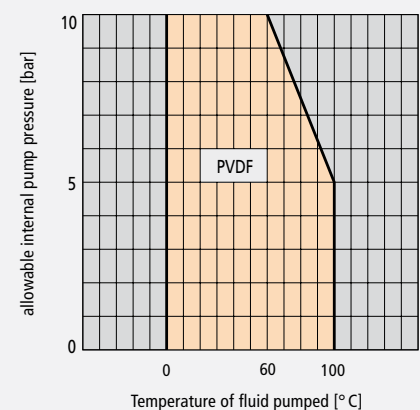
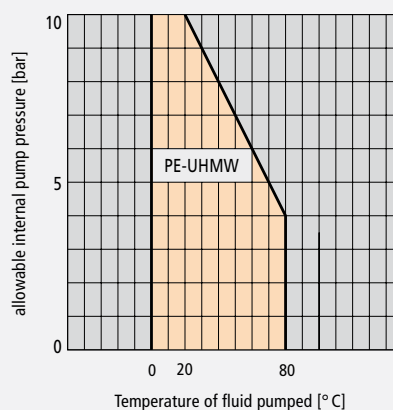
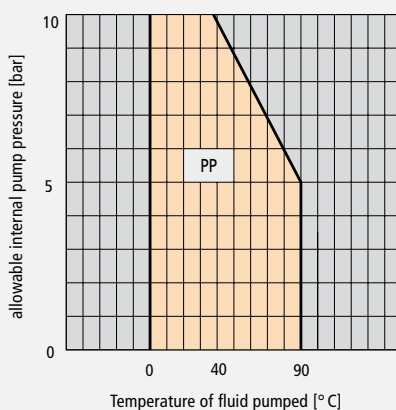

The above maximum allowable service pressures and temperatures relate to the standard pump design. Higher pressure and temperature applications possible in consultation with MUNSCH GmbH.

## Design features

- 1 Flexible coupling connecting motor shaft to pump shaft.
- 2 Anti-friction bearing integrated into the bearing lantern allows high loads to the shaft.
- 3 Column pipe with 90° elbow and flange; connection by a suitable pipe union allows the column pipe and/or the discharge flange to be rotated to virtually any position (Fig. 3.1). Option: column pipe with flange, screw joint or design to customer's specification. (Fig. 3.2)
- 4 Steel shaft with solid plastic protection sleeve.
- 5 Vertical setting depth variable in steps of 100 mm (standard); intermediate setting depths possible.
- 6 Pump casing, casing cover and suspension pipe made of solid plastics; with sufficient abrasion allowance; maximum reliability when handling corrosives and abrasives.
- 7 Solid impeller hub ensures plastics stability even at high temperatures.
- 8 Impeller: closed and semi-open designs available.
- 9 Optimum hydraulic design using the latest numerical methods ensures: good suction behaviour due to low NPSH requirements, minimum mechanical vibration of components, long service lives of antifriction and plain bearings, minimized running noise.
- 10 Impeller is positively locked to the shaft for reverse rotation protection.
- 11 Standard motor, design V1 with canopy.

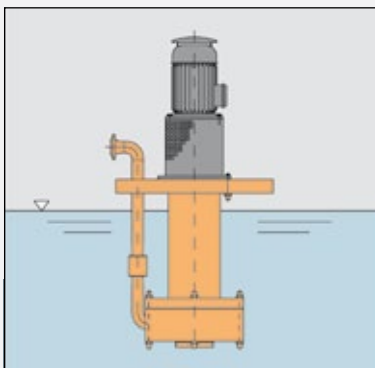
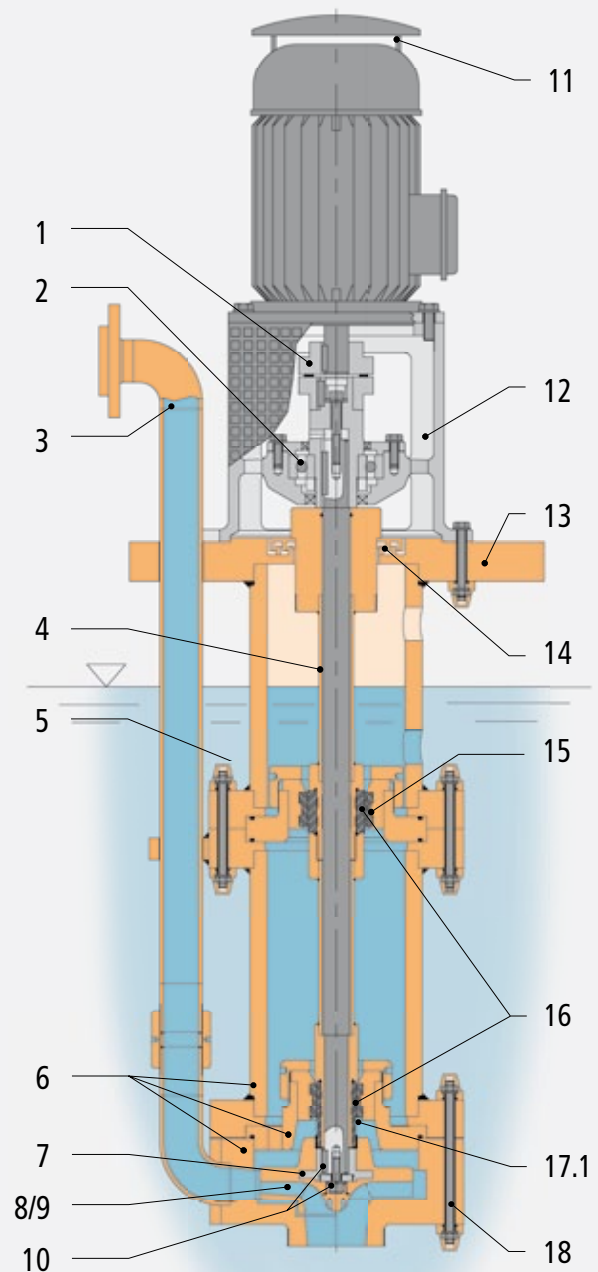

3.1) With flange and elbow, wet-end installation

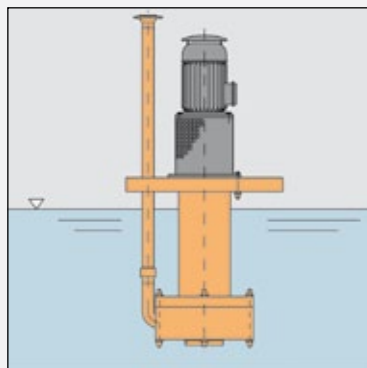

3.2) With top flange, wet-end installation

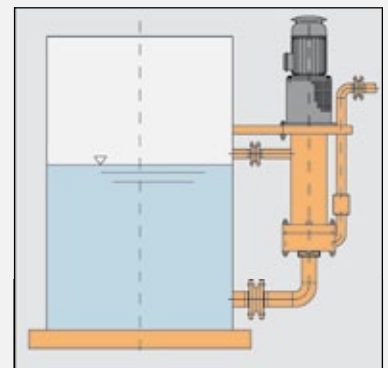

3.3) With flange and elbow, dry-end installation

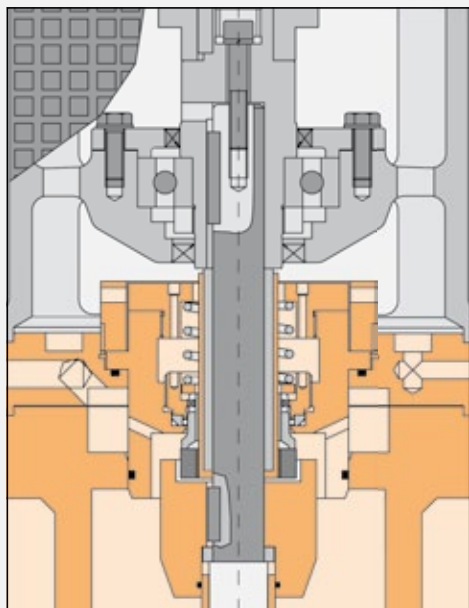

14.1

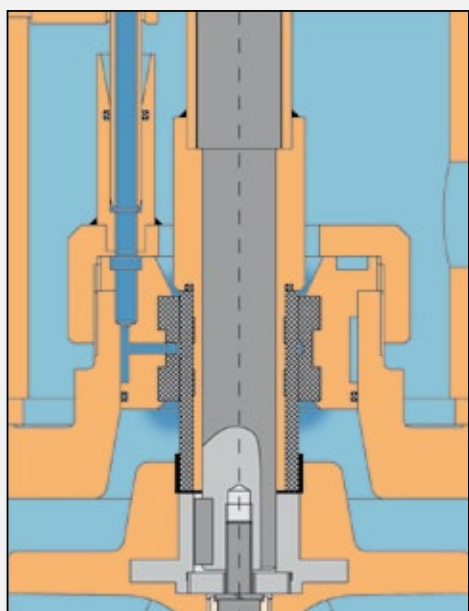

17.2

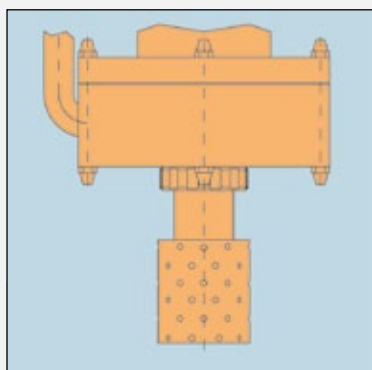

19) With suction strainer and suction pipe

- 12 Low external height above, slim construction below the sole plate; TNP-KL can still be installed, where conventional pump configurations face a space problem.
- 13 Circular sole plate; special sole plate dimensions and sole plates with additional supporting flange (tank cover) available on request.
- 14 Contact-free Type 10 labyrinth seal integrated into the sole plate.
- 14.1 Single mechanical seal (option): The single mechanical seal is used when there is an aboveatmospheric or negative pressure in the pump tank, the fluid pumped tends to vaporize or poses an environmental hazard. Lubrication of mechanical seal by fluid pumped or external flushing source.
- 15 The intermediate bearing is required for large vertical setting depths (speed-dependent) to effectively prevent radial shaft deflection.
- 16 Plain bearing fabricated from silicon carbide. This advanced silicon carbide not only offers extreme wear resistance but is also resistant to virtually all acids and alkalis.
- 17.1 Lower plain bearing made of universally chemical-resistant SSiC, product-lubricated.
- 17.2 External flushing system for plain bearing necessary when the fluid pumped is loaded with solids or tends to crystallize (the figure shows the lower plain bearing).
- 18 The screw connections (threaded rods and cap nuts) reliably absorb the maximum internal casing pressures arising. Corrosion protection is achieved by plastic coating and plastic cap nuts with O-rings to prevent contact with the medium pumped.

### ► Accessories / Options

- 19.1 Suction strainer
- 19.2 Suction pipe up to a length of 1600 mm,
- 19.3 Suction strainer and suction pipe,
- 20 Motor overload switch (not shown).

### ► Explosion protection to EU Directive 94/9/EG (option)

Additional constructional measures allow the use of the TNP-KL in explosion hazard areas. The pump meets the requirements of EU Directive No. 94/9/EG.

► Performance characteristic charts

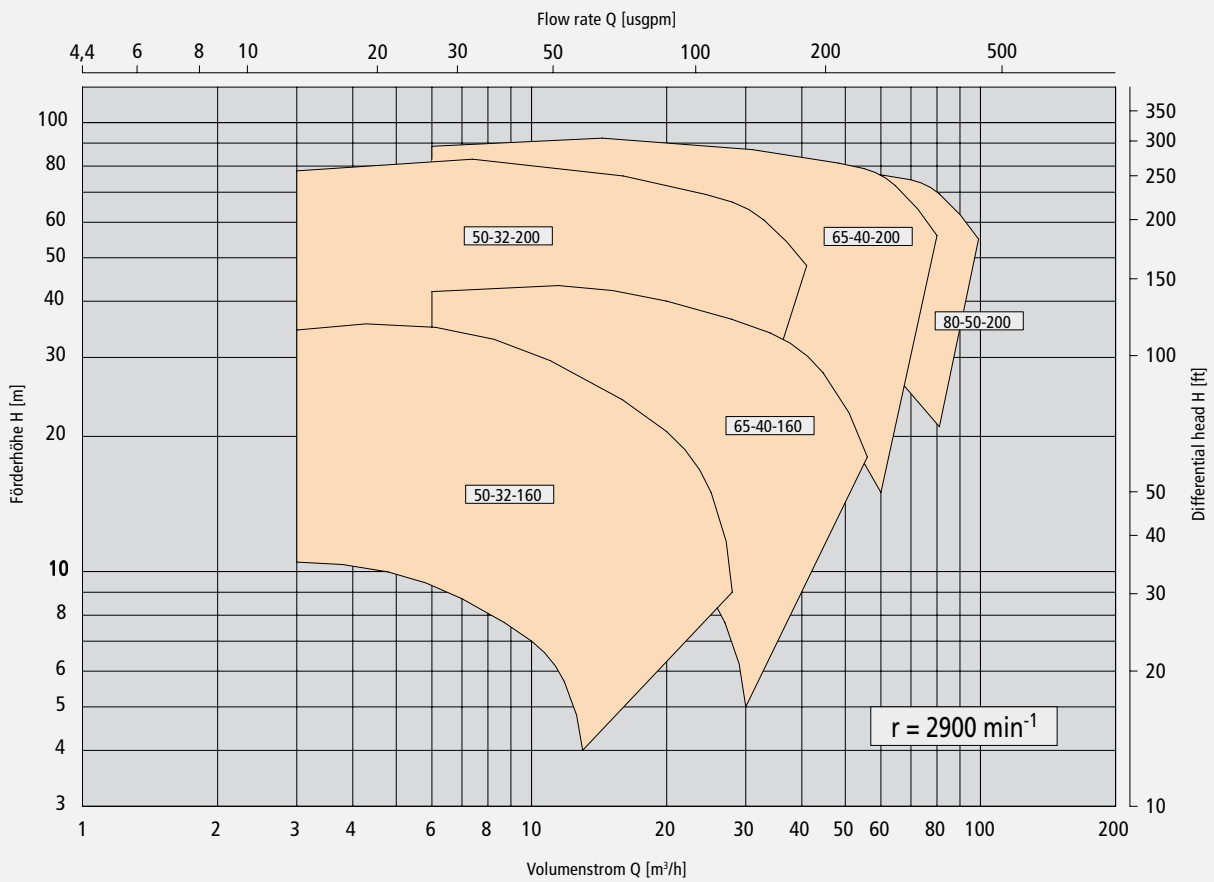
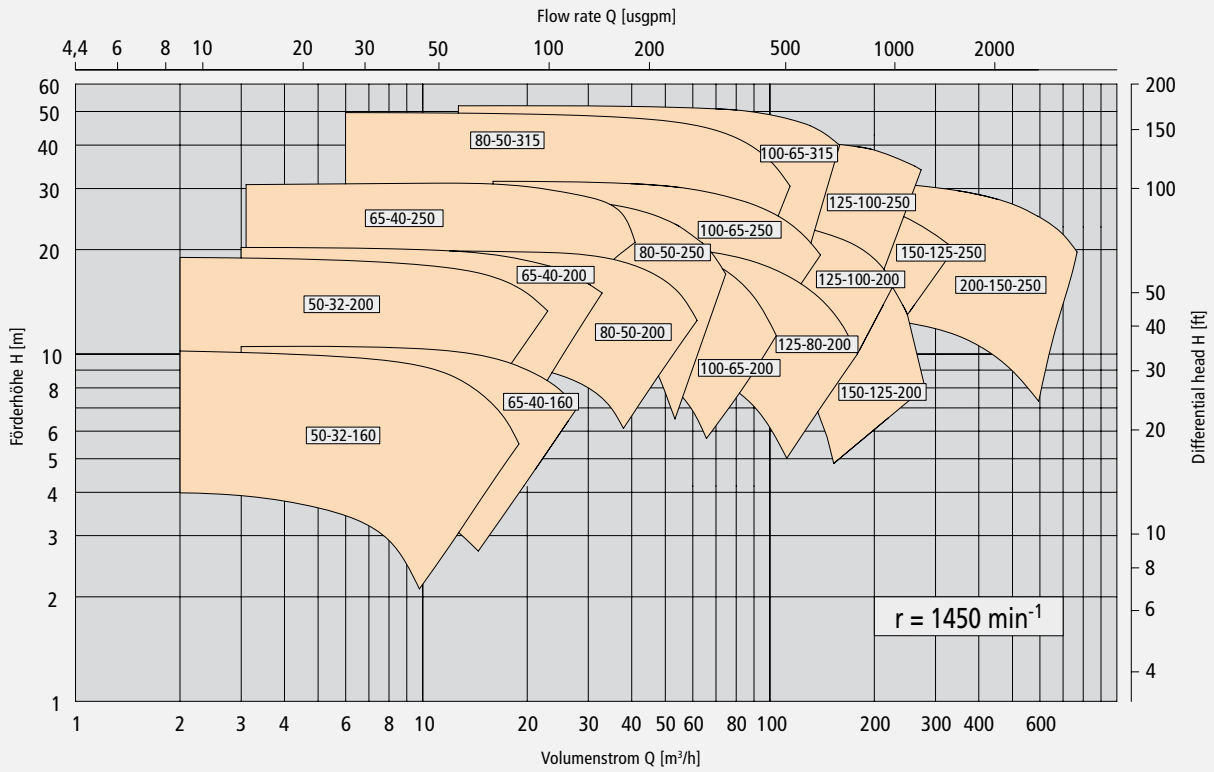

# Vertical chemical pump TNP-KL

## ► Dimensions – Standard design

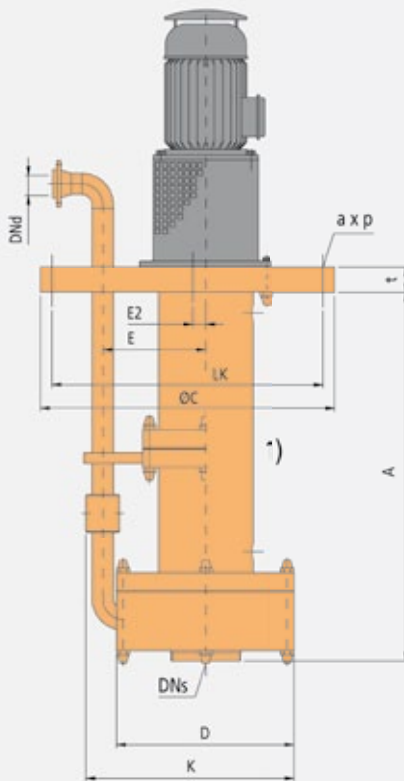

Pump size	DNd	DNs	a	ØC	D	E	E2	K	LK	p	t
50-32-160	32	50	4	480	295	180	0	365	440	12,5	45
50-32-200	32	50	6	540	370	225	20	445	508	12,5	50
65-40-160	40	65	4	480	295	180	0	370	440	12,5	45
65-40-200	40	65	6	540	370	225	20	450	508	12,5	50
65-40-250	40	65	8	590	425	245	45	485	558	12,5	60
80-50-200	50	80	6	540	370	225	20	455	508	12,5	50
80-50-250	50	80	8	590	425	245	45	490	558	12,5	60
80-50-315	50	80	10	700	520	285	20	595	668	12,5	60
100-65-200	65	100	8	590	425	245	45	500	558	12,5	60
100-65-250	65	100	8	640	450	250	20	525	608	12,5	60
100-65-315	65	100	10	700	520	285	20	595	668	12,5	60
125-80-200	80	125	8	590	425	245	45	515	558	12,5	60
125-100-200	100	125	10	700	460	305	60	600	668	12,5	60
125-100-250	100	125	10	760	520	340	50	670	728	12,5	60
150-125-200	125	150	10	800	600	340	45	720	768	12,5	70
150-125-250	125	150	10	800	600	340	60	710	768	12,5	70
200-150-250	150	200	10	950	700	400	60	830	918	12,5	70

1) For TNP-KL with and without intermediate bearing, see table "Range of vertical setting depths"

Range of vertical setting depths [A] as a function of motor speed		
Speed [1/min]	TNP-KL without intermediate bearing	TNP-KL with intermediate bearing
750	400-1600	1600-3000
860	400-1600	1600-3000
950	400-1600	1600-3000
1150	400-1600	1600-3000
1450	400-1600	1600-3000
1750	400-1400	1400-2600
2900	400-1200	-
3500	400-1000	-

- Dimensions in [mm]  
 - For motor dimensions, please refer to motor catalogue  
 - Weights depend on vertical setting depth and motor size;  
 please contact manufacturer for exact data

## ► Sole plate

The pump is supplied with a circular sole plate (1) as standard; rectangular sole plate (2) and supporting flange (3) as well as sole plate designed to customers specification can be supplied on request.

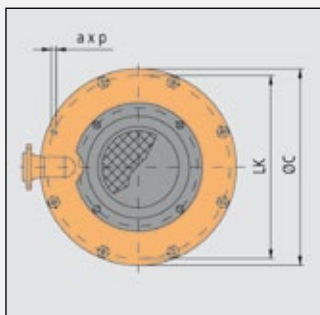

1) Circular sole plate; standard

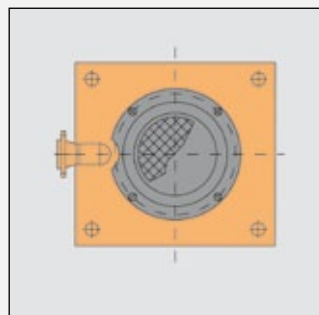

2) Rectangular sole plate;  
special design on request

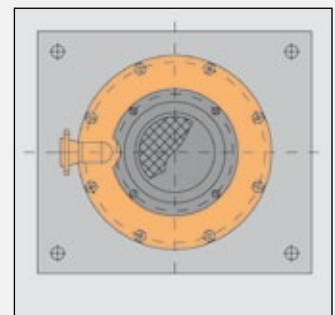

3) Circular sole plate with supporting flange;  
special design on request

**MUNSCH Chemie-Pumpen GmbH**  
 Im Staudchen · D-56235 Ransbach-Baumbach  
 P.O. Box 142 · D-56221 Ransbach-Baumbach  
 Germany  
 Phone: +49 (0) 2623-898-90  
 Fax: +49 (0) 2623-898-95  
 Internet: <http://www.munsch.de>  
 E-Mail: [munsch@munsch.de](mailto:munsch@munsch.de)